

FILED  
SUPREME COURT  
STATE OF WASHINGTON  
9/1/2022 10:15 AM  
BY ERIN L. LENNON  
CLERK

from court of Appeals Div. III and II  
No. 38563-9-III, cons. with 38755-I-III

SUPREME COURT OF THE  
STATE OF WASHINGTON  
CAUSE No. 100959-3

---

RICHARD PLECHNER,

Petitioner.

---

MOTION FOR DISCRETIONARY REVIEW  
FROM THE COURT OF APPEALS, DIVISION III

---

Richard Plechner  
DOC# 975117  
Washington State Penitentiary  
1313 North 13<sup>th</sup> Avenue  
Walla Walla, WA 99362

## TABLE OF CONTENTS

Identity of Petitioner .....	1
Appellate Decision to be Reviewed.....	1
Issues Presented for Review .....	1
Statement of the Case .....	2
Argument .....	5
Conclusion .....	12

## TABLE OF AUTHORITIES

<i>Hart v. Gomez</i> , 174 F.3d 1067, 1073 (9th Cir. 1999)....	12
<i>In re Nichols</i> , 171 Wash.2d370 (2011).....	6
<i>State v. Harper</i> , 64 Wash. App. 283 (1992).....	6
<i>State v. McFarland</i> , 127 Wash.2d 322 (1995) .....	6
<i>State v. Williams</i> , 96 Wash.2d 215 (1981) .....	9

## APPENDIX

Appendix A: *State v. Plechner*, No. 38563-9-III,  
consolidated with *In re Pers. Restraint of Plechner*, No.  
38755-1-III (May 3, 2022)

Appendix B: Ruling of Commissioner Schmidt (January  
5, 2021)

Appendix C: Supplemental Filing Cover Page (filed  
August 5, 2021)

I. IDENTITY OF PETITIONER

Appellant Richard Plechner, pro se and indigent, asks this court to accept review of the decision designated in Part II of this motion.

II. APPELLATE DECISION TO BE REVIEWED

Petitioner requests that the Washington State Supreme Court review and reverse the Washington State Court of Appeals decision in *State v. Plechner*, No. 38563-9-III, consolidated with *In re Pers. Restraint of Plechner*, No. 38755-1-III. A copy of this decision is attached as Appendix A.

III. ISSUES PRESENTED FOR REVIEW

- 1) Did the Court of Appeals err when it refused to consider evidence outside the record in evaluating Mr. Plechner's Personal Restraint Petition?
- 2) Did the Court of Appeals fail to apply the proper standard when evaluating whether new evidence attached to Mr. Plechner's petition warranted relief?

3) Did the Court of Appeals fail to consider all relevant facts when assessing Mr. Plechner's claims of ineffective assistance of counsel?

#### IV. STATEMENT OF THE CASE

After the conclusion of his criminal trial, Mr. Plechner filed both a personal restraint petition and a direct appeal in the Court of Appeals, Division II. On January 5, 2021, the Commissioner of Division II ordered that Mr. Plechner's PRP should be consolidated with his direct appeal. Ruling by Commissioner Schmidt, attached as Appendix B. The Commissioner further ordered that "respondent may file a single response addressing both the appeal and this petition." *Id.* On January 6, 2021, Mr. Plechner filed a supplement to his PRP containing additional evidence, which the court construed as a Motion to Supplement and granted.

On August 9, 2021, Mr. Plechner filed a document in Division II entitled "Supplemental Statement of Additional Grounds and Supplemental P.R.P. (pro-se) (with exhibits)" (hereafter "Supplemental Filing").

Supplemental Filing Cover Page, attached as Appendix C. Mr. Plechner clearly intended this document to serve as both a Statement of Additional Grounds and a supplement to his PRP, given that they had been consolidated into a single case. He attached several exhibits to this filing with the intent that they be considered in his PRP, including a photograph which conflicts with the account of Tina Gumm (whose testimony formed the sole basis for Mr. Plechner's conviction) and a police report which also contradicts Ms. Gumm's testimony. He made several arguments in this filing which relied on the articles of evidence he had attached, including that the newly discovered evidence warrants a new trial; that his rights under the Confrontation Clause had been violated; that his trial counsel, Gene Austin, was ineffective; and others. On November 15, 2021, the court permitted Mr. Plechner to further supplement this document with an additional exhibit outside the record, a signed declaration by Jasmine Palma, whose testimony would have contradicted Ms. Gumm's.

On December 2, 2021, Mr. Plechner was informed that in order to expedite review, his consolidated appeal and PRP were transferred to Division III of the Court of Appeals.

In its unpublished opinion filed May 3, 2022, the Court of Appeals, Division III seemed to regard Mr. Plechner's August 2, 2021 filing solely as a statement of additional grounds:

The accused may attach or reference only documents contained in the record in a statement of additional grounds. The accused must assert errors involving facts or evidence not in the record through a personal restraint petition, not a pro se statement of additional grounds.

*State v. Plechner* at 24 (citations omitted).

Regarding the photograph included in Mr. Plechner's supplemental filing as "Exhibit B," the court wrote that "Because this argument arises from new evidence not introduced at trial, we address this contention when responding to Plechner's personal restraint petition." *Id.*

The court proceeded to reject all other arguments in Mr. Plechner's supplemental filing which relied on the attached exhibits. The court refused to consider Mr. Plechner's argument that the State committed *Brady* violations, writing that "Plechner cites to materials outside of the trial record contrary to the rules of a statement of additional grounds." *Id.* at 25. The court refused to consider Mr. Plechner's argument that his trial counsel was ineffective, writing that "To the extent they are not duplicative [of appellant counsel's briefing], Plechner's arguments are inscrutable or request this court to consider materials outside of the trial court record." *Id.* at 26.

The court affirmed Mr. Plechner's conviction and dismissed his PRP without a reference hearing. *Id.* at 27.

#### V. ARGUMENT

- 1) The Court of Appeals erred when it refused to consider evidence outside the record when evaluating Mr. Plechner's PRP.

A personal restraint petition is the appropriate vehicle to seek relief from a judgment based on materials

outside the trial record. *State v. McFarland*, 127 Wash.2d 322, 335 (1995). In a PRP, both the appellant and the State are permitted to submit evidence outside the existing record. *In re Nichols*, 171 Wash.2d 370, 375 (2011). Where a direct appeal is consolidated with a PRP, and a filing is responsive to both proceedings, the reviewing court may treat references to materials outside the record as having been raised in the PRP. *See State v. Harper*, 64 Wash. App. 283, 289 n.3 (1992) (“While this evidence is outside the record and cannot be considered on the direct appeal, it can be considered as part of the consolidated petition[.]”).

The Court of Appeals, Division II, clearly regarded Mr. Plechner’s Supplemental Filing as both a statement of additional grounds and a supplement to his PRP, when they granted his motion to further supplement his filing with an additional affidavit not contained in the trial record. Further, that the court never made Mr. Plechner aware that his filing was in any way deficient, nor ordered



him to amend it, demonstrates that it intended to consider the attached evidence as having been raised in his PRP.

The Division III court's failure to treat Mr. Plechner's filing as a PRP has resulted in an unjust and inequitable outcome. Several of the claims in Mr. Plechner's PRP rely on evidence outside the trial record, including his claims of newly-discovered evidence, *Brady* violations, and ineffective assistance of counsel. Were the courts' dismissal of his PRP to stand, Mr. Plechner would be forced to raise these arguments in a successive PRP, having already raised them in his initial PRP proceeding in Division II.

It is possible that there was a misunderstanding or loss of nuance when Mr. Plechner's consolidated case was transferred to Division III in order to expedite review, and a new panel of judges confronted the lengthy and somewhat fraught procedural history of Mr. Plechner's case with fresh eyes. However, Mr. Plechner (a pro se litigant) should not bear the cost of that misunderstanding. At a minimum, the evidence he attached to his

Supplemental Filing presents a sufficient case to justify a reference hearing.

Accordingly, Mr. Plechner's petition should be remanded for consideration of the new evidence attached to his Supplemental Filing and, if necessary, a reference hearing should be ordered.

- 2) The Court of Appeals did not apply the proper standard when evaluating whether the photograph attached to Mr. Plechner's PRP warranted relief.

To the extent that the Court of Appeals gave any consideration to the additional evidence submitted by Mr. Plechner, it did not apply the correct and well-settled legal standard.

To adjudge a claim of newly-discovered evidence in a PRP, the reviewing court must determine whether the evidence (1) will probably change the result of the trial, (2) was discovered since the trial, (3) could not have been discovered before trial by the exercise of due diligence, (4) is material, and (5) is not merely cumulative or

impeaching. *State v. Williams*, 96 Wash.2d 215, 223 (1981).

The analysis performed by the Court of Appeals bears no resemblance to this well-established test. The Court of Appeals wrote:

Assuming admissibility of the photograph, Richard Plechner does not establish a complete miscarriage of justice. The jury could have interpreted the photograph to support Tina Gumm's testimony. Assuming Plechner took the photograph of Tina Gumm on the day of the alleged crime, the photograph supports Gumm's testimony that she and Plechner were together that morning and that Plechner enjoyed the opportunity to commit the crime before taking the photo.

*State v. Plechner* at 27. Rather than determine whether the photograph would "probably change the result of trial," the court found only that there was some conceivable way the jury "could have" interpreted the new evidence and ended its analysis.

The ability to construct some hypothetical in which the jury finds some new evidence unpersuasive has no bearing on the probability that that evidence would create a reasonable doubt in the minds of a jury.

In-other-words; the "Test" is: If any jurist could find the new evidence persusaive enough to have a conclusion other than a finding of "Guilty". More-over; the lower courts "Logic" is stated in a very misleading way. The court said;"Plechner enjoyed the opportunity to commit the crime "BEFORE" taking the photo." Here; the court is concluding that: First, the alleged crime was committed...then the photograph of "Tina Gumm" was taken at; "8:23 a.m." "AFTER" she was allegedly assaulted. This is a full 53 minutes after 7:30 a.m. Further; the trial testimony of Tina Gumm shows the following:

Page 386 @ line no.4 "Q. Your testimony was on the 18th. around 7:30 a.m. you woke up...were you wrong about that?"

Page 386 @ line no.6 "A. No."

Page 238 @ line no.6 "Q. And you went straight out the door is that correct?"

Page 238 @ line no.7 "A. Yes."

Page 144 @ line no.19 "A. I kind of like exploded, you know, to try to expand my space and asked where my dogs were, I just got up off the bed and reached for the door looking for my dogs and he had put my dogs outside of the room."

A reasonable jurist would have found this testimony totally incongruent with the photograph that not only shows Tina Gumm, but also her dog on my bed 53 minutes after the alleged assault supposedly happend. No where in the Trial Transcript does Tina refer to having her photograph taken "AFTER" being assaulted or how she returned to my house and bed 53 minutes after going to the Am./Pm. More-over; the "Shelton Police Report" and the statement of "Jasmine Palma" each support the authenticity of the photograph. Clearly the lower court did not give this evidence a fair review.

Furthermore, where a defendant presents multiple items of newly-discovered evidence, their probable effect on the outcome of a trial should be considered collectively, not item-by-item. As stated above, the Court of Appeals considered only one article of newly discovered evidence; the photograph attached to Mr. Plechner's earlier filing. It did not consider the other exhibits attached by Mr. Plechner (the police report and the signed declaration by Jasmine Palma). Even if the court had performed the proper analysis on the likely impact of the photograph, the photograph cannot be considered in isolation but must be considered collectively with all other articles of newly-discovered evidence.

To fairly review Mr. Plechner's claims, the Court of Appeals must consider whether the aggregate effect of a photograph, a police report, and a signed declaration – all of which contradict the testimony of the State's only direct witness – warrant relief from the judgment.

Accordingly, Mr. Plechner's petition should be remanded for reconsideration under the correct legal

standard and, if necessary, a reference hearing should be ordered.

- 3) The Court of Appeals did not consider all relevant evidence pertaining to Mr. Plechner's claim of ineffective assistance of counsel.

Because the Court of Appeals incorrectly refused to consider materials outside the record when evaluating Mr. Plechner's claim of ineffective assistance of counsel, it did not conduct a full and fair analysis.

The evidence attached to Mr. Plechner's Supplemental Filing must be considered, as it weighs in favor of a finding of ineffective assistance of counsel. For example, the signed declaration of Jasmine Palma establishes that Gene Austin, Mr. Plechner's attorney, failed to investigate and call a witness whose testimony would have corroborated Mr. Plechner's account. *See Hart v. Gomez*, 174 F.3d 1067, 1073 (9th Cir. 1999) ("When defense counsel fails to introduce . . . Evidence that corroborates a key defense witness whom the jury might

otherwise not believe – confidence in the outcome is necessarily undermined.”).

Because the Court of Appeals failed to consider this evidence, its analysis of Mr. Plechner's ineffective assistance claim is incomplete.

Accordingly, Mr. Plechner's petition should be remanded for full consideration of all relevant evidence and, if necessary, a reference hearing should be ordered.

Further; now that the corona-virus pandemic is basically over, this case should be sent back to Division Two.

#### VI. CONCLUSION

Based on the above, this Court should grant discretionary review.

DATED this 31<sup>st</sup> day of  
August, 2022.

Respectfully submitted,

Rich Plechner

Richard Plechner

# Appendix A



FILED  
MAY 3, 2022  
In the Office of the Clerk of Court  
WA State Court of Appeals Division III

IN THE COURT OF APPEALS OF THE STATE OF WASHINGTON  
DIVISION THREE

STATE OF WASHINGTON,	)	
	)	
Respondent,	)	No. 38563-9-III consolidated with
	)	No. 38755-1-III
v.	)	
	)	
RICHARD ANTHONY PLECHNER,	)	UNPUBLISHED OPINION
	)	
Appellant.	)	
	)	
<hr/>	)	
In the Matter of the Personal Restraint of:	)	
	)	
RICHARD ANTHONY PLECHNER	)	
	)	

FEARING, J. — In attacking his convictions for indecent liberties and assault in the fourth degree with sexual motivation, Richard Plechner forwards numerous assignments of error by way of an appeal, statement of additional grounds (SAG), and a personal restraint petition. We reject all contentions and affirm his conviction.

FACTS

We gather the facts from the trial testimony of Tina Gumm, the victim. Tina Gumm met Richard Plechner while she resided at the home of Leslie Ellerbrock. Gumm

described Plechner as neither friend nor sexual partner. After departing from the Ellerbrock home, Gumm dwelled in other homes and shelters, and occasionally saw Plechner. At some unidentified time, the car of Jasmine Palma, Plechner's girlfriend, struck Gumm's car.

On September 17, 2019, Tina Gumm encountered Richard Plechner on the street outside a domestic violence shelter. Plechner informed Gumm that her car had been damaged. Gumm had yet to see the damage. She had slept the previous two nights in another car she owned.

Between the hours of 11 p.m. and 3:30 a.m. on September 17-18, Tina Gumm visited Plechner's house to inquire about the car. After speaking with Plechner, Gumm fell asleep on a bed in his house. At 7:30 a.m., Gumm awoke to feel Plechner's hands inside her pants and in contact with her vagina.

Despite the nonconsenting and intimate contact, Tina Gumm drove Richard Plechner that morning to WalMart and an AM/PM mart. She then accompanied Plechner to the domestic violence shelter to view the damage to Gumm's car.

In late September 2019, Tina Gumm lodged at Jasmine Palma's house for two days. At 10:00 a.m. on one of these mornings, Palma and Richard Plechner, while inside Palma's residence, locked Gumm outside as she smoked a cigarette. Either Plechner or Palma called the police. The police arrived at the residence and directed Gumm to leave Palma's address. On October 3, 2019, two or more days after her expulsion from

No. 38563-9-III cons. with 38755-1-III  
*State v. Plechner; Personal Restraint of Plechner*

Palma's residence, Gumm reported the touching of her vagina by Plechner to the Shelton Police Department.

#### PROCEDURE

The State of Washington charged Richard Plechner with one count of indecent liberties with a victim incapable of consent by reason of being physically helpless to have sexual contact and one count of assault in the fourth degree with sexual motivation. Eugene Austin represented Richard Plechner at trial, and Tyler Bickerton represented the State. The jury trial began on January 8, 2020.

Before voir dire on January 8, defense counsel Eugene Austin expressed confusion about the indecent liberties charge. He commented to the trial court that he had believed the State based the charge on forcible compulsion under RCW 9A.44.100(1)(a). The information instead alleged, under RCW 9A.44.100(1)(b), that the victim could not consent by reason of being physically helpless.

Attorney Eugene Austin contemplated calling Jasmine Palma as a trial witness. As a result, the court appointed attorney Peter Jones to represent Palma because of pending charges against her stemming from the damage to Tina Gumm's vehicle. Palma's trial testimony could implicate her. Jones advised that Palma intended to invoke her Fifth Amendment to the United States Constitution right if asked any questions at trial.

After Jasmine Palma's announcement about invoking her right to remain silent, defense counsel Eugene Austin interjected that Richard Plechner wished for replacement trial counsel. Plechner directly addressed the trial court and insisted he had a right to subpoena witnesses. Plechner added that he directed Austin to call Palma to testify, but that Austin now refused. Plechner desired Palma's testimony that Tina Gumm had blackmailed Palma with threats to report a hit-and-run accident to the police.

Peter Jones, who also served as public defense administrator for Mason County, commented that no other public defender would be able to otherwise address Richard Plechner's concerns about the refusal to summon Jasmine Palma to testify. After questioning by the trial court, Plechner concluded he did not wish to fire Eugene Austin as his trial counsel. The court invited Plechner to relay any future impasse with Austin.

After jury voir dire, Eugene Austin informed the trial court anew that Richard Plechner wished new counsel or to proceed pro se. Plechner complained to the court that Austin failed to aggressively advocate on Plechner's behalf and that he suffered ineffective assistance of counsel. The trial court declined to appoint new counsel.

After completion of voir dire, trial resumed on Friday, January 10, 2020. The State called Tina Gumm as its first witness. Gumm identified Richard Plechner as the one who placed his hand in her pants and on her vagina. Gumm added that Plechner previously resided in jail while she resided in Leslie Ellerbrock's domicile. In the absence of the jury, Eugene Austin, on behalf of Plechner, requested a curative

instruction for the jury to ignore Gumm's statement that Plechner had been in jail. Plechner, on behalf of himself, demanded a curative instruction that told the jury that the State dismissed the prosecution, for which he had resided in jail. Attorney Austin misunderstood Plechner's request and believed Plechner wanted to ask for the current case to be dismissed. The trial court correctly heard Plechner's request and rejected the giving of Plechner's preferred instruction. Austin withdrew the request for a more limited curative instruction.

Tina Gumm's testimony resumed. She related a history of domestic violence and experiences with posttraumatic stress disorder (PTSD) stemming from the violence. The court excused the jury to hear contentions between defense counsel and the State's attorney relating to Gumm's testimony on these topics. Defense counsel remarked:

Mr. Plechner believes that—that [Gunn]—she went back the last time to meet with—with [her ex-boyfriend] Steve so that she could steal his truck. And that she could—then after—and if I'm—she stole the truck. And that she then wanted Jasmine to assist her in—in her case, but Jasmine was—was with Mr. Plechner and she needed Mr. Plechner—and she ends up—they have a falling out and she needs Mr. Plechner to get her—her back into good—good graces.

I think even if we went down that line she would have to take the Fifth and it would—my—my—my—my interest was just to understand her motivation behind doing what she—her actions—her whole course of actions.

Report of Proceedings (RP) at 229-30. The prosecuting attorney voiced frustration:

—for the record, it appears Mr. Austin is proceeding ethically and following the rules. However he's making a record of his client who seems to not understand the rules, who is not an attorney. And I—I—I appreciate

him putting it on the record for purposes of appeal. But perhaps this needs to be a conversation with Mr. Plechner that that's inadmissible. I don't see how that comes in, regardless of—I don't think that there's any foundation that could be set that gets to that end result of answering—asking the question, having—did you steal a car, were you charged with, because I'm objecting to all that.

. . . It seems each issue that is causing delay in this trial and causing conflict is Mr. Plechner interjecting with inadmissible and improper questions or argument.

RP at 231-32. The court deferred to defense counsel about whether he wished to pursue further questioning relating to Gumm stealing a car. Counsel did not pursue this line of questioning. The court recessed for the weekend.

The State rested on Tuesday, January 14, 2020, after interrogating the police officer who interviewed Tina Gumm. The State asked the officer to identify Richard Plechner. After the officer commented that Plechner was present at counsel table, attorney Eugene Austin asked that the officer clarify which of the two people sitting at defense counsel was Plechner. The officer replied that Plechner wore a blue striped collared shirt.

Outside the presence of the jury on January 14, defense counsel Eugene Austin informed the court that Richard Plechner told Austin that someone left a note on Plechner's door during the weekend. Plechner claimed he discovered the note on Monday night outside his door and that Tina Gumm had written the note. The note declared: "have your attorney put Tina back on the stand. Have him ask her one question." RP at 274; see also SAG at 38. Austin had not yet located Gumm to demand

her return for further testimony. The court recessed the trial until the next morning to afford the defense time to locate Gumm.

The court reconvened on January 15, 2020. In the absence of the jury, Eugene Austin notified the court of another communication from Tina Gumm. Jasmine Palma had forwarded to Richard Plechner a text message from Gumm. Attorney Austin called Palma to testify as an offer of proof of the contents of the text message. Palma testified that Gumm wrote about uncertainty of whether to continue with the prosecution against Plechner and that she was unsure about the events of the night in question. Palma related that the text message had been deleted from her phone, but that she had forwarded the original message to Plechner. Palma then read to the court the contents of the lengthy text message from Gumm:

I didn't think you'd answer. I wanted Richard's attorney [sic] phone number. The prosecutor gave it to me and I forgot it. I'm in Bremerton having a nervous breakdown on my way to my neighbor's—to my neighbor's house—apartment. I already missed twice. Nothing can ever be simple. Everything had to be something big fucking production.

I'm so fucking angry and my life plans, my dreams, my opportunities, my ability to function, my personal belongings, my beautiful innocent little dogs, my relationship, my credibility, and my sense of belonging, my trust, my sense of safety and my identity—not my name, but who I am has all been violated and decimated. There isn't anything about me or my life that I recognize anymore, or that's worth claiming.

The sheriff's already told me I was wrong about what [Gumm's abusive ex-boyfriend] Steve has done to me. And they said I was mentally ill. The DV shelter said I was wrong about Steve and said I'm emotionally sick. Mason General Hospital and the clinics told me I had psychiatric issues and that I was wrong about thinking I've been abused and exposed to

toxins, and told me I needed to leave; that they would not treat me for any physical issues until I see a psychiatric doctor first.

Then the only thing I'm left to believe is that I could be wrong about Richard hurting me. I need the attorney's number. I cannot make it to court until tomorrow.

RP at 333-34.

The State's attorney objected to the court's consideration of the text message based on the grounds of lack of authentication, the best evidence rule, and hearsay. The court ruled that the text message constituted hearsay not subject to an exception.

Eugene Austin, on behalf of Richard Plechner, moved for a witness warrant to compel the attendance of Tina Gumm to testify again since the trial court had not released her as a witness. The State responded:

It seems every step of the way what defense has tried to accomplish within the past two days, going from this alleged note that was placed on the Defendant's door, to this alleged text message that was sent to Ms. Palma, is that it's all speculation. There is nothing that they have from the mouth of Tina Gumm in regards to anything that they would put on to the case. There is no materiality here, and nothing has been asserted to the Court by the defense.

RP at 344-45. Before the State finished its argument, Gumm arrived at the courthouse ready to testify.

Before the jury entered the courtroom to hear additional testimony, defense counsel Eugene Austin informed the trial court that Richard Plechner wished for him to pursue a line of questioning in potential violation of a motion in limine. The court recognized the disagreement but informed Austin that he remained responsible for



deciding the line of questioning to pursue. Austin next informed the court that Plechner wished to fire him. The court asked Plechner if he wished to proceed pro se. Plechner responded that he still wanted a lawyer.

Tina Gumm assumed the witness stand. Gumm then testified:

Q [ATTORNEY AUSTIN] Okay. Have you ever indicated to anyone that you—that you were mistaken?

A [TINA GUMM] I sent a text message to Jasmine where I was trying to—so I've been to the sheriff's office so many times about my ex and—and nothing's ever happened. So I feel like I'm being brainwashed to believe that I can't trust myself. So—so in the text message I said that—

{TYLER} BICKERTON: I'm going to object to—as hearsay in the text message.

THE COURT: Sustained.

RP at 377-78. Austin did not pose any further questions about the text message. Austin successfully introduced the handwritten note into evidence, and Gumm admitted that she had left the note at Plechner's door. On cross-examination, the State's attorney asked Gumm whether she had been mistaken in relating any of the events that occurred when she slept on the bed at Plechner's home. Gumm responded that she had not been mistaken.

Defense counsel called Leslie Ellerbrock as the defense's final witness.

Ellerbrock declared that Tina Gumm and Richard Plechner had met while Gumm resided in Ellerbrock's spare bedroom and that Gumm exhibited hostility toward Plechner. Ellerbrock testified that Gumm had lived in her household for eight months before Ellerbrock expelled her.

One jury instruction read: "A touching is offensive if the touching would offend an ordinary person who is not unduly sensitive." Clerk's Papers at 80.

The prosecuting attorney remarked during closing:

I want to start this off by saying there's nothing I say right now for the next 10, 15 minutes, or when I come back in rebuttal, that will be evidence. You're not to consider anything I say as evidence. The evidence came from that chair and that chair alone. That goes for Mr. Austin as well. If I say something that doesn't sound right, or I mis-remembered, remember, you guys have that instruction as well. Maybe I wrote something down, maybe I misheard something, or maybe I'm mis-analyzing something. This is all up for you to decide. Everything that came out of the mouth of the witness[es] is for you to decide. Right now I am just arguing *what I believe*, and what the State believes is the theory of the case.

RP at 455 (emphasis added). Defense counsel did not object to these introductory remarks.

The State's attorney analyzed the law of assault during closing:

An assault is an intentional touching or—or touching of another person that is harmful or offensive, regardless of whether any physical injury is done to that person. So it's going to be up to you 12 individuals to decide, would the touching of an individual's intimate area be harmful or offensive. *Would any one of you be offended if your intimate area was touched?* That is the question of this assault. I submit to you absolutely.

And the definition further goes, *a touching is offensive if the touching would offend an ordinary person who is not unduly sensitive*. So the question is once again, would an ordinary person be sensitive to the fact of letting another man, if you were a female, touch their vagina? Or perhaps if you were a man having a woman touch your penis? Or any way of this axis, it doesn't matter. . . .

I submit to you the touching of an intimate area is offensive. And it is not—and it is not to the level of an ordinary person who would be

sensitive, 'cause I'd submit to you each and every one of us would be the same.

RP at 461-62 (emphasis added). Defense counsel did not object to the prosecutor's characterization of the law of assault.

The State's attorney attacked the defense's theory:

The defense wants you to believe that Ms. Tina Gumm made up this whole story; that she fabricated it, because of past instances with Richard Plechner. But at the same time, they're attacking her retelling stories, remembering facts. With all due respect to counsel, I'd submit to you, *he's talking out of both sides of his mouth*. On one hand he's putting down Ms. Gumm stating she can't remember anything, she's lived a tough life, she has PTSD, she has anxiety. But then on the other hand he's telling she has been able to concoct this whole story, to fabricate this story, all just to convict Richard Plechner. Does that make sense to you? That's going to be something I want you to consider.

On one hand Ms. Gumm who, by all accounts has had difficulties, could she come up with this whole story? And he's basing it on three instances. He's basing it on an incident with the Ellerbrocks who—she lived at her house. And you heard Ms. Ellerbrock said I kicked her out. I want you to think about her testimony, think about her credibility. I'd submit to you, she was a smug and non-caring individual with the world.

And I'll also submit to you, *that was a rehearsed, coached testimony*. Every point of her testimony—

MR. AUSTIN: Your Honor, I'm going to object to that—that comment.

M, MR. BICKERTON: It's argument.

MR. AUSTIN: I know, but she—he—she's—he's impugning defense counsel, as well as the—as—as the witness without any sort of basis on it.

MR. BICKERTON: It's argument. I'm getting to the basis.

THE COURT: It's argument, overruled.

MR. BICKERTON: Witness took that stand, and every question I asked, what'd she do? She paused waiting for an objection, or actually was trying to think of legal objections in her head, and making comments herself, or looking to the Judge, can I ask—can I answer, can I—can I not

answer this? I asked a question, nothing was answered, and she still paused. She didn't even want to answer. Why? I submit to you because she didn't know how she was supposed to answer. No, instead the whole time she stared directly at these two. She stared at her friend. She stared at her friend, the same person who she said she would invite over for dinner tonight. She said that last night. She would have invited him over for dinner. Do you want to take her story into question? Call her into question?

And they want you to believe that because Ms. Gumm was kicked out of the house of the Filcbrock's in July, that August, September, October—August, September, sorry, two months later she concocted a story that he sexually assaulted her because of that? No. I submit to you no.

RP at 477-79 (emphasis added).

During closing, the prosecuting attorney discussed Richard Plechner's and Tina

Gumm's interactions:

You heard her testify how scared she was, how she stated that she had PTSD, mental trauma, she's in fear, she's scared, she has anxiety of stalking. That's the life she's lived. She also stated that Mr. Plechner talks a lot, he's loud, he talks fast, he's controlling, he gives directions, he manipulates, he causes friction, and he causes distrust—distrust. She testified that anyone Mr. Plechner talks to, he attempts to control, attempts to influence.

That's what Mr. Plechner wants to do—wanted to do in this trial. He tried to control, he tried to influence. And I submit to you, it didn't work. And that the 12 of you are going to find him guilty—

MR. AUSTIN: Objection, Your—Your Honor—

MR. BICKERTON: —of two counts—

THE COURT: Just a moment, there's an objection.

MR. AUSTIN: Objection. I—I—I think, you know, asserting that—that—could we—could we discuss this outside the jury? 'Cause I'm going to be—

MR. BICKERTON: Can we have a quick side bar?

THE COURT: Side bar.

MR. AUSTIN: That's fine.

No. 38563-9-III cons. with 38755-1-III  
*State v. Plechner; Personal Restraint of Plechner*

**SIDE BAR CONFERENCE**

Side bar at the request of defense counsel off the record.

**THE COURT:** Overruled.

RP at 480-81. After excusing the jury to begin their deliberations, the court explained that it had overruled defense counsel's objection at the side bar. Defense counsel had complained during the side bar that the prosecuting attorney had referenced the delays of trial as being Plechner's fault.

The jury returned guilty verdicts on both charges.

**LAW AND ANALYSIS**

On appeal, Richard Plechner asserts numerous assignments of error in his appellate counsel's brief, his statement of additional grounds, and a personal restraint petition. He contends the trial court infringed on his constitutional rights to counsel, effective counsel, and to confront his accusers and the prosecuting attorney engaged in misconduct. We separate arguments asserted in the three filings, starting with appellate counsel's brief.

**Right to Counsel**

Richard Plechner first contends that the trial court failed to honor his constitutional right to counsel when refusing to appoint him a new attorney when effective communications between attorney Eugene Austin and himself ended. Plechner adds that the trial court failed to conduct a sufficient investigation into the nature and impact of the conflict between his counsel and him. We note that, when questioned by the trial court,

No. 38563-9-III cons. with 38755-1-III  
*State v. Plechner; Personal Restraint of Plechner*

Plechner stated he wanted an attorney and never expressly asked for a new attorney. We review this argument anyway.

An indigent defendant does not have the inexorable right to be represented by a lawyer of his choosing. *Wheat v. United States*, 486 U.S. 153, 159, 108 S. Ct. 1692, 100 L. Ed. 2d 140 (1988). But when the relationship between lawyer and defendant completely collapses, the refusal to substitute new counsel violates the defendant's Sixth Amendment right to effective assistance of counsel. *In re Personal Restraint of Stenson*, 142 Wn.2d 710, 722, 16 P.3d 1 (2001). When an indigent defendant fails to provide legitimate reasons for the assignment of substitute counsel, the court may require the defendant to either continue with current counsel or to proceed pro se. *State v. DeWeese*, 117 Wn.2d 369, 376, 816 P.2d 1 (1991). The factors considered in determining whether an irreconcilable conflict exists include (1) the extent of the conflict, (2) the adequacy of the trial court's inquiry, and (3) the timeliness of the motion. *United States v. Moore*, 159 F.3d 1154, 1158-59 (9th Cir. 1998); *In re Personal Restraint of Stenson*, 142 Wn.2d 710, 724 (2001). An adequate inquiry must include a full inquiry of the differences between the accused and his counsel. *State v. Cross*, 156 Wn.2d 580, 610, 132 P.3d 80 (2006), *abrogated on other grounds by State v. Gregory*, 192 Wn.2d 1, 427 P.3d 621 (2018). When the request for change of counsel comes during the trial, or on the eve of trial, the court may, in the exercise of its sound discretion, refuse to delay the trial to obtain new

No. 38563-9-III cons. with 38755-I-III  
*State v. Plechner; Personal Restraint of Plechner*

counsel and therefore may reject the request. *United States v. Williams*, 594 F.2d 1258, 1260 (9th Cir. 1979); *In re Personal Restraint of Stenson*, 142 Wn.2d 710, 732 (2001).

Disagreement about trial strategy does not violate a defendant's constitutional rights, unless the disagreement actually compromises the attorney's ability to provide adequate representation. *State v. Cross*, 156 Wn.2d 580, 611 (2006). Although a client decides the goals of litigation and whether to exercise some constitutional rights, the attorney determines the means. *State v. Cross*, 156 Wn.2d at 606.

Richard Plechner and his counsel, Eugene Austin, encountered a strained relationship. Nevertheless, the conflict related to trial strategy. Plechner disputed his attorney's refusal to call a witness, attempted to direct specific questions to ask a witness on the stand, and hoped to introduce new evidence at trial. Each time a conflict arose, the trial court conducted adequate inquiries into the attorney-client relationship. The court repeatedly heard concerns from both Plechner and Austin and concluded that the differences did not implicate a disagreement of constitutional magnitude. Each conflict fell into territory allocated to defense counsel for decision-making. Plechner's complaints were untimely. Thus, we discern no error.

Our Supreme Court has found no irreconcilable conflict with more substantial disagreements between counsel and defendant. In *State v. Cross*, 156 Wn.2d 580 (2006), defense counsel's decision not to present a substantive defense and instead focus on arguments regarding the defendant's mental capacity did not create irreconcilable

No. 38563-9-III cons. with 38755-1-III  
*State v. Plechner; Personal Restraint of Plechner*

conflict. In *In re Personal Restraint of Stenson*, 142 Wn.2d 710 (2001), defense counsel's determination that the guilt phase of a case "could not be won" because of overwhelming evidence did not justify a finding of irreconcilable conflict.

#### Right of Confrontation

Richard Plechner next contends that the trial court denied his right of confrontation by improperly excluding evidence of the complaining witness's bias. Amendment VI of the United States Constitution and article 1, section 22 of the Washington Constitution protect a defendant's right to confront an adverse witness. Primarily, the confrontation right protects a defendant's ability to cross-examine witnesses. *Douglas v. Alabama*, 380 U.S. 415, 418-19, 85 S. Ct. 1074, 13 L. Ed. 2d 934 (1965). Through cross-examination, a defendant may test the perception, memory, and credibility of witnesses, which helps assure the accuracy of the fact-finding process. *State v. Darden*, 145 Wn.2d 612, 620, 41 P.3d 1189 (2002).

Richard Plechner argues that the trial court violated his right to confrontation by limiting cross-examination about Tina Gumm's pending auto theft charges. Nevertheless, the court never limited cross-examination on this topic. Plechner's trial counsel did not pursue questioning relating to the auto theft charges, but only informed the trial court that Plechner wished to pursue the questions. Without a trial court ruling on the matter, this court has no basis to find error. We address Plechner's contention that



his trial counsel should have questioned Gunn on pending charges in his assignment of ineffective assistance of counsel.

#### Prosecutorial Misconduct

Richard Plechner contends the State's attorney engaged in misconduct with four categories of remarks during closing statement: when declaring his personal opinion regarding Plechner's guilt, when misstating the law of assault, when impugning defense counsel, and when referencing evidence outside the record. Plechner also requests that we view the cumulative impact of the misconduct when determining whether to reverse his conviction.

To establish prosecutorial misconduct, a defendant must show that the prosecuting attorney's remarks were both improper and prejudicial. *State v. Allen*, 182 Wn.2d 364, 373, 341 P.3d 268 (2015). The burden to establish prejudice requires a defendant to prove a substantial likelihood that the instances of misconduct affected the jury's verdict. *State v. Thorgerson*, 172 Wn.2d 438, 442-43, 258 P.3d 43 (2011).

Trial defense counsel did not object to any of the challenged comments by the prosecuting attorney. When a defendant fails to object to improper remarks at trial, the defendant waives review of the error unless the remarks were so flagrant and ill intentioned that they caused an enduring and resulting prejudice that could not have been neutralized by an admonition to the jury. *State v. Slater*, 197 Wn.2d 660, 681, 486 P.3d 873 (2021). The "flagrant and ill intentioned" standard sets a higher bar for reversal than

the “improper and prejudicial” standard and applies only in a narrow set of cases when the court holds concern about the jury drawing improper inferences from the evidence. *State v. Loughom*, 196 Wn.2d 64, 74, 470 P.3d 499 (2020). Under this heightened standard, the defendant must show (1) no curative instruction would have obviated any prejudicial effect on the jury and (2) there is a substantial likelihood that the misconduct affected the jury’s verdict. *State v. Emery*, 174 Wn.2d 741, 761, 278 P.3d 653 (2012).

Richard Plechner first argues that the prosecutor gave a personal opinion of Plechner’s guilt when he intoned: “Right now I am just arguing what I believe, and what the State believes is the theory of the case.” RP at 455. A prosecutor should avoid expressing a personal opinion of guilt. *In re Personal Restraint of Glasmann*, 175 Wn.2d 696, 706, 286 P.3d 673 (2012). Nevertheless, we conclude that the State’s attorney expressed no personal opinion as to the guilt of Richard Plechner. When read in context, his mentioning of what he believed referenced what he believed to be theories of the case, not what he personally believed to be the facts or the validity of the prosecution against Plechner. The State’s attorney had earlier stated that his representations concerning the facts did not constitute facts.

Richard Plechner next argues that the prosecutor misstated the law of assault to the jury when he asked jurors to determine whether each would have been offended if he or she was touched in intimate areas. Such a subjective standard conflicts with the law’s

No. 38563-9-111 cons. with 38755-1-111  
*State v. Plechner; Personal Restraint of Plechner*

requirement that a touching be offensive to an ordinary person who is not unduly sensitive. *State v. Smith*, 159 Wn.2d 778, 781, 154 P.3d 873 (2007).

A prosecutor's argument to the jury must be confined to the law stated in the trial court's instructions. *State v. Estill*, 80 Wn.2d 196, 199, 492 P.2d 1037 (1972). A misstatement of the law may constitute prosecutorial misconduct. *State v. Davenport*, 100 Wn.2d 757, 761-65, 675 P.2d 1213 (1984). When the prosecutor mischaracterizes the law and there is a substantial likelihood that the misstatement affected the jury verdict, the accused is denied a fair trial. *State v. Gotcher*, 52 Wn. App. 350, 355, 759 P.2d 1216 (1988).

*State v. Walker*, 164 Wn. App. 724, 265 P.3d 191 (2011), *adhered to on remand*, 173 Wn. App. 1027 (2013) (unpublished), informs our decision. During closing in a prosecution against Aquarius Walker for first degree murder, the State's attorney informed the jury that the defense of others standard would be met if the jury would have taken the same action in defense. This remark misstated the law establishing an objective test for defense of others. The law and the jury instruction did not allow the jury to substitute subjective belief with an objective test or standard based on a reasonable person. The prosecuting attorney repeated his theme of a subjective standard seven times, once after an objection by defense counsel. A PowerPoint slide instructed the jury that the test to apply was whether "I would do it too, if I knew what he knew." *State v. Walker*, 164 Wn. App. 724, 735-36 (2011). This court ruled that the prosecuting attorney

committed misconduct. The cumulative effect of this misconduct with other improper arguments required a reversal.

We agree with Richard Plechner that the State's attorney misstated the law. We decline reversal, however, because we conclude the error did not likely affect the verdict. The prosecutor only uttered the mistake once, and we rule that he did not commit other misconduct. Practically all persons would consider touching of private parts to be offensive. The critical question for the jury was whether the touching occurred, not whether the touching of the vaginal area constituted offensive behavior to a reasonable person.

Richard Plechner argues that the prosecutor unfairly impugned defense counsel. Plechner complains that the prosecuting attorney accused trial counsel of coaching a witness on her testimony. The State's attorney's intoned: "that was a rehearsed, coached testimony." RP at 478. Plechner does not complain about the State's attorney's accusation toward defense counsel of "talking out of both sides of his mouth." RP at 477.

A prosecutor must not impugn the role or integrity of defense counsel. *State v. Lindsay*, 180 Wn.2d 423, 431-32, 326 P.3d 125 (2014). Our Supreme Court has found prejudice when a prosecutor impugned opposing counsel by describing defense tactics as "'bogus'" and "'sleight of hand.'" *State v. Thorgerson*, 172 Wn.2d 438, 450-52 (2011).

Richard Plechner's prosecuting attorney directed the contested comments at witness Leslie Ellerbrock because she purportedly tailored her testimony to be favorable

No. 38563-9-111 cons. with 38755-1-111  
*State v. Plechner; Personal Restraint of Plechner*

to Plechner. When doing so, the prosecutor highlighted aspects of the Ellerbrock's behavior during testimony and suggested those behaviors diminished her credibility. The State's attorney never identified defense counsel as the coach of Ellerbrock. Thus, we conclude that the prosecutor's accusations did not target defense counsel.

Richard Plechner next contends that the prosecutor referred to evidence outside of the record when the State's attorney mentioned that Plechner sought to control and manipulate Tina Gumm. Plechner contends that this argument by the State implicated him for repeatedly delaying the trial. A prosecutor may not remark on facts not in evidence, although he may argue reasonable inferences from the evidence. *State v. Russell*, 125 Wn.2d 24, 87-88, 882 P.2d 747 (1994). Although the prosecutor had expressed earlier concern about Plechner causing delays in trial, the closing argument was untethered from any trial continuances. The prosecutor could reasonably draw inferences from other evidence of the manipulative nature of Plechner.

Finally, Richard Plechner assigns cumulative error given the volume of prosecutorial misconduct at trial. He does not cite to any case supporting his argument that this court may find cumulative error even if no individual instance of misconduct prejudiced the jury against him. The cumulative error doctrine does not apply when the errors are few and have little or no effect on the outcome of the trial. *State v. Weber*, 159 Wn.2d 252, 279, 149 P.3d 646 (2006). We find one instance of misconduct that did not impact the jury verdict.

### Ineffective Assistance of Counsel

To demonstrate ineffective assistance of counsel, a defendant must make two showings: (1) defense counsel's representation fell below an objective standard of reasonableness and (2) defense counsel's deficient representation prejudiced the defendant. *Strickland v. Washington*, 466 U.S. 668, 687, 104 S. Ct. 2052, 80 L. Ed. 2d 674 (1984); *State v. Vazquez*, 198 Wn.2d 239, 247-48, 494 P.3d 424 (2021). Courts indulge a strong presumption that counsel is effective. *State v. Vazquez*, 198 Wn.2d 239, 247.

A defendant must first show that trial counsel's performance fell below an objective standard of reasonableness based on consideration of all the circumstances. When doing so, the defendant must show in the record the absence of legitimate strategic or tactical reasons supporting the challenged conduct by counsel. *State v. Vazquez*, 198 Wn.2d 239, 248 (2021); *State v. McFarland*, 127 Wn.2d 322, 336, 899 P.2d 1251 (1995).

Richard Plechner faults his trial counsel for failing to impeach the credibility of accuser Tina Gumm with a text message in which she questioned her memory of the events comprising the alleged crime. Gumm began to testify about the text message. The State's attorney objected on hearsay grounds, and the trial court sustained the objection. Defense counsel did not further attempt to impeach Gumm with the text message.

Richard Plechner's briefing on appeal fails to address whether the hearsay rule precluded admission or use of the text message to impeach the complaining witness. Without Plechner's demonstration of the admissibility of the text message, we cannot find counsel's representation ineffective.

Richard Plechner also argues that defense counsel performed ineffectively for failing to impeach Tina Gumm with a pending auto theft charge. A party may impeach a witness with a crime only after a criminal conviction. ER 609(a). Plechner does not establish that his defense counsel could have employed a pending charge for impeachment.

Richard Plechner assigns error to defense counsel's failure to object to prosecutorial misconduct for expressing a personal opinion and misstating the law of assault. We already ruled that the State's attorney did not express a personal opinion. Assuming defense counsel performed inadequately for failing to object to the prosecutor arguing a subjective standard for offensive touching, we have already ruled that Plechner shows no prejudice.

Richard Plechner highlights his trial counsel's confusion on the first day of trial over the indecent liberty charge. Plechner does not establish that any confusion affected the trial strategy or prejudiced him. Richard Plechner further argues that defense counsel assisted in Plechner's in-court identification by requesting the police officer to clarify whether counsel or Plechner was the defendant. Given that the jury witnessed defense

counsel making legal arguments, the jury would have assumed that Plechner was the defendant. Tina Gumm had also identified Plechner.

Finally, Richard Plechner also asserts that multiple attorney/client conversations within the hearing of others in the courtroom prejudiced him. The record does not support a conclusion that these interactions occurred in the presence of the jury.

#### Statement of Additional Grounds

We address eight assignments of error asserted in Richard Plechner's statement of additional grounds. First, Plechner maintains that a photograph not introduced at trial proved his innocence. Because this argument arises from new evidence not introduced at trial, we address this contention when responding to Plechner's personal restraint petition. The accused may attach or reference only documents contained in the record in a statement of additional grounds. RAP 10.10(c). The accused must assert errors involving facts or evidence not in the record through a personal restraint petition, not a pro se statement of additional grounds. *State v. Calvin*, 176 Wn. App. 1, 26, 316 P.3d 496 (2013), *remanded on other grounds*, 183 Wn.2d 1013, 353 P.3d 640 (2015).

Second, Richard Plechner contends the trial court denied him his Sixth Amendment right to confrontation. This argument duplicates his appellant counsel's briefing.



Third, the trial court failed to permit his calling Jasmine Palma as a witness. Nevertheless, Plechner possessed no such right. His attorney's decision not to call Palma as a witness fell within the attorney's reasonable judgment in determining trial strategy.

Fourth, the State and the Shelton Police Department failed to collect and preserve materially exculpatory evidence. Plechner cites to materials outside of the trial record contrary to the rules of a statement of additional grounds.

Fifth, according to Richard Plechner, the State committed prosecutorial misconduct. Plechner's appellant's brief raised the issue of prosecutorial misconduct, but Plechner identifies additional conduct of the prosecuting attorney in his statement of additional grounds as grounds for reversal. Plechner argues that the prosecutor should not have commented about Plechner's supposed beliefs and Tina Gumm's credibility. Nevertheless, a prosecutor may make reasonable inferences from the evidence and make arguments regarding witness credibility. Plechner argues that the prosecutor's polite interactions with Tina Gumm constituted prosecutorial misconduct. We disagree, and Plechner cites no law to support this contention. Finally, Plechner complains that the prosecutor argued that Plechner was fabricating evidence throughout Plechner's attempts to introduce new evidence at trial. These arguments, outside the presence of the jury, could have had no prejudicial effect on the jury's verdict.

Sixth, Richard Plechner maintains that insufficient evidence supported his conviction. The test for sufficiency of evidence is whether, after viewing the evidence in

No. 38563-9-III cons. with 38755-1-III  
*State v. Plechner; Personal Restraint of Plechner*

the light most favorable to the State, any rational trier of fact could have found the essential elements of the crime beyond a reasonable doubt. *State v. Hosier*, 157 Wn.2d 1, 8, 133 P.3d 936 (2006). A reviewing court defers to the fact finder on issues of witness credibility, testimony, and persuasiveness of the evidence. *State v. Rodriguez*, 187 Wn. App. 922, 930, 352 P.3d 200 (2015). The jury could have reasonably credited Tina Gumm's testimony in convicting Richard Plechner.

Seventh, Richard Plechner argues his trial counsel performed ineffectively. These contentions duplicate appellant counsel's briefing. To the extent they are not duplicative, Plechner's arguments are inscrutable or request this court to consider materials outside of the trial court record.

Eighth, the trial court committed an abuse of discretion when allowing Eugene Austin to continue to represent him at trial despite an irreconcilable conflict. This argument also echoes contentions raised in the appellant's brief.

#### Personal Restraint Petition

In a personal restraint petition, Richard Plechner argues that a photograph not introduced at trial proves his innocence.

To obtain relief with a personal restraint petition, a petitioner must establish either constitutional error that caused actual and substantial prejudice or a nonconstitutional error that constituted a fundamental defect resulting in a complete miscarriage of justice. *In re Personal Restraint of Davis*, 152 Wn.2d 647, 671-72, 101 P.3d 1 (2004). The

photograph forwarded by Richard Plechner depicts a woman lying down. The purported date and time of the photograph, September 18, 2019 at 8:23 a.m., floats above the photograph. Plechner contends he snapped the photograph.

Assuming admissibility of the photograph, Richard Plechner does not establish a complete miscarriage of justice. The jury could have interpreted the photograph to support Tina Gumm's testimony. Assuming Plechner took the photograph of Tina Gumm on the day of the alleged crime, the photograph supports Gumm's testimony that she and Plechner were together that morning and that Plechner enjoyed the opportunity to commit the crime before taking the photo.

#### CONCLUSION

We affirm Richard Plechner's conviction and dismiss his personal restraint petition.

A majority of the panel has determined this opinion will not be printed in the Washington Appellate Reports, but it will be filed for public record pursuant to RCW 2.06.040.

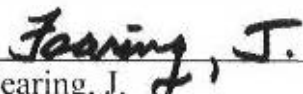
  
Fearing, J.

WE CONCUR:

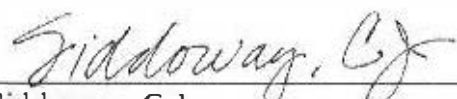
  
Siddoway, C.J.

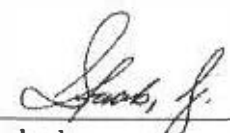
  
Staab, J.

## **Appendix B**



Washington State Court of Appeals  
Division Two

909 A Street, Suite 200, Tacoma, Washington 98402

Derek Byrne, Clerk/Administrator: (253) 593 2970 (253) 593 2806 (Fax)

General Orders, Calendar Dates, and General Information, at <http://www.courts.wa.gov/courts> OFFICE HOURS 9-12, 1-4

January 5, 2021

Richard Plechner  
DOC #975117  
Washington Corrections Center  
PO Box 900  
Shelton, WA 98584

Timothy W Whitehead  
Mason County Prosecutors Office  
PO Box 639  
Shelton, WA 98584-0639

CASE #: 55293-1-II  
Personal Restraint Petition of: Richard Plechner

Counsel:

On the above date, this court entered the following notation ruling:

**A RULING BY COMMISSIONER SCHMIDT**

This court, on its own initiative, consolidates this petition with Petitioner's direct appeal, State v. Plechner, No. 54676-1-II. All future correspondence should refer to case no. 54676-1-II. Respondent may file a single response addressing both the appeal and this petition. The response due date will be set according to the perfection letter in the appeal.

Very truly yours,

Derek M. Byrne  
Court Clerk

## **Appendix C**

IN THE COURT OF APPEALS OF THE STATE OF WASHINGTON

DIVISION II

State of Washington  
Respondents,  
v.s.  
RICHARD PLESHNER,  
Appellant.

No. <sup>\*</sup> 54676-1-2

Appealed from:

Mason County Cause No. 19-1-00359-23

SUPPLEMENTAL STATEMENT OF  
ADDITIONAL GROUNDS AND SUPPLEMENTAL  
P.R.P. (pro-se) (with exhibits)

1 HEAR COMES; RICHARD PLESHNER, appellant who was charged  
2 with indecent liberties, based on a single, false allegation, made  
3 by Tina Gumm who changed her story no less than four times!!! For  
4 example the Trial Transcript (T.T.), on page no. 334 @ line no. 13.) gives  
5 you; "Then the only thing I'm left to believe is that I could be wrong,  
6 about Richard hurting me... I need the attorney's number... I cannot  
7 make it to court until tomorrow." (see: exhibit "E"). This court  
8 ordered; "Mixed Petition", shows that the prosecutor knew from the start,  
9 or discovered shortly later that Tina lied about material facts at my  
10 trial. This is why this court needs to either reverse or dismiss my  
11 conviction. The issues I list in this petition are not inclusive and  
12 I ask this court to grant me relief on any grounds it see's fit to do  
13 so. I also ask this court to incorporate a earlier P.R.P. I sent this  
14 court, in this petition. (It has some case law in it that the prison  
15 either lost or will not give back to me, after I had been transported.).



US006145488A

# United States Patent [19]

[11] Patent Number: 6,145,488

Plechner

[45] Date of Patent: Nov. 14, 2000

[54] REDUCED VOLUME SCAVENGING SYSTEM FOR TWO CYCLE ENGINES

Primary Examiner—Marguerite McMahon  
Attorney, Agent, or Firm—Brian J. Coyne

[75] Inveor: Richard A. Plechner, Shelton, Wash

[57] ABSTRACT

[73] Assignees: MPM Motors, Inc.; Miles Way Coyne, P.L.C., both of Olympia, Wash.

A reduced volume scavenging system for a two cycle engine embodying a duplex cylinder having an upper cylinder bore and a reduced diameter lower cylinder bore. The lower bore communicates with a crankcase that houses a crankshaft, connecting rod(s) and engine lubricating oil. A fixed sleeve lines the upper cylinder bore and extends up into the cylinder head. A piston disposed for reciprocating motion within the fixed sleeve has an attached cylindrical, reciprocating sleeve that extends down into the lower cylinder bore and moves with the piston. The reciprocating sleeve has compression rings that seal the lower bore and the crankcase against blowby gases that might contaminate the oil. The fixed sleeve has an intake opening in registry with an inlet port in the upper cylinder bore for admission of fresh air/fuel mixture. The fixed sleeve also has an exhaust opening diametrically opposite the intake opening and in registry with an exhaust port in the upper cylinder bore, as well as upper and lower pairs of scavenging openings in registry with transfer passageways recessed into the upper cylinder bore, such that each out stroke of the piston forces fresh air/fuel mixture through the passageways and into the combustion chamber to flush out burnt gases. This arrangement permits use of four cycle engine lubricating methods and apparatus in two cycle engines, without unduly adding to their weight and complexity, thereby reducing the emission of air pollutants and increasing engine life.

[21] Appl. No.: 09/354,447

[22] Filed: Jul. 15, 1999

[51] Int. Cl.<sup>7</sup> ..... F02B 33/14

[52] U.S. Cl. .... 123/193.1; 123/193.6; 123/73 1; 123/65 S; 123/193.2

[58] Field of Search ..... 123/73 F, 73 FA, 123/73 AA, 73 C, 65 S, 65 P, 193.1, 193.2, 193.6, 193.4

### [56] References Cited

#### U.S. PATENT DOCUMENTS

1,472,549	10/1923	Burnell	
1,672,869	6/1928	Buckman	
1,802,585	4/1931	Stokes	
1,900,475	3/1933	Winqvist	
2,127,758	8/1938	Schmitz	
2,923,284	2/1960	De Isartia	123/73 F
3,749,066	7/1973	Cseh	123/65 S
4,068,629	1/1978	Hooper	123/65 S
4,481,909	11/1984	Takada et al.	123/73 F
4,796,872	1/1989	Heydrich	123/193.2
5,724,933	3/1998	Silvonen et al.	123/193.6
5,857,450	1/1999	Staezel	123/65 S

36 Claims, 16 Drawing Sheets

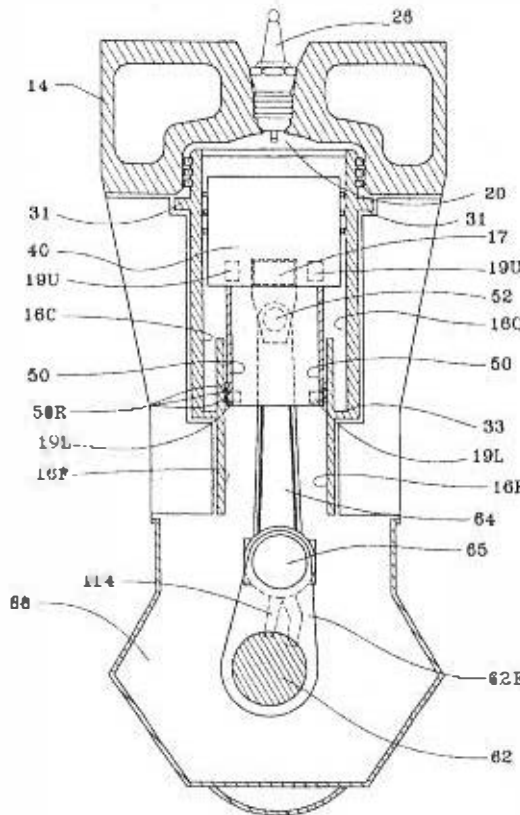



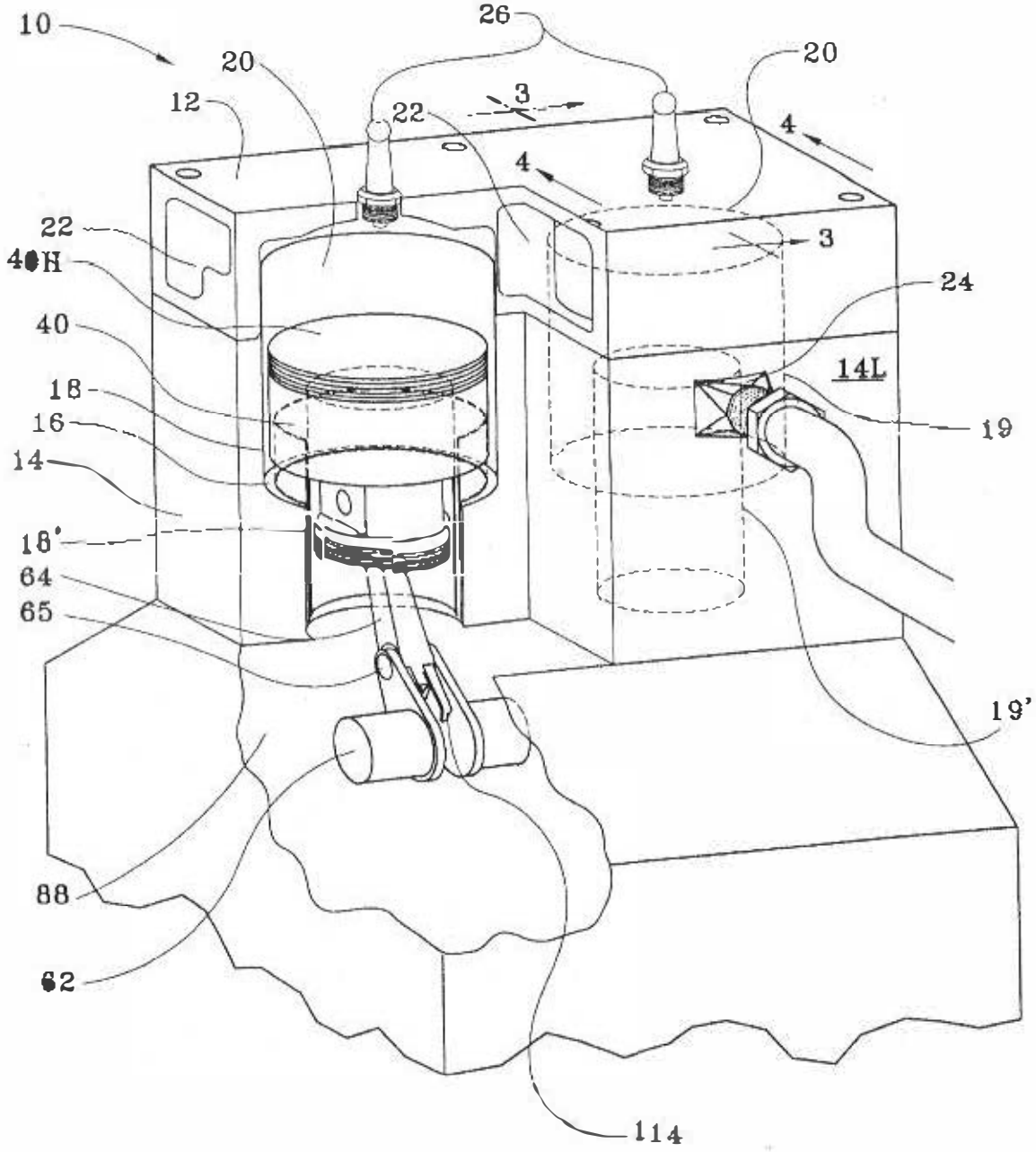

FIG. 2

# INMATE

September 1, 2022 - 10:15 AM

## Transmittal Information

**Filed with Court:** Supreme Court  
**Appellate Court Case Number:** 100,959-3  
**Appellate Court Case Title:** State of Washington v. Richard Anthony Plechner  
**Superior Court Case Number:** 19-1-00359-6

DOC filing of PLECHNER Inmate DOC Number 975117

### The following documents have been uploaded:

- 1009593\_20220901101517SC412973\_9119\_InmateFiling.pdf {ts '2022-09-01 10:01:59'}

*The Original File Name was DOC1pWAL1061@doc1.wa.gov\_20220901\_113858.pdf*

The DOC Facility Name is Washington State Penitentiary.

The Inmate The Inmate/Filer's Last Name is PLECHNER.

The Inmate DOC Number is 975117.

The CaseNumber is 1009593.

The Comment is 1OF1.

The entire original email subject is 15,PLECHNER,975117,1009593,1OF1.

The email contained the following message:

External Email Warning! This email has originated from outside of the Washington State Courts Network. Do not click links or open attachments unless you recognize the sender, are expecting the email, and know the content is safe. If a link sends you to a website where you are asked to validate using your Account and Password, DO NOT DO SO! Instead, report the incident. Reply to: DOC1pWAL1061@doc1.wa.gov <DOC1pWAL1061@doc1.wa.gov>  
Device Name: DOC1pWAL1061 Device Model: MX-M365N Location: WAL1-B40 SC 2nd Fl, Ell File Format: PDF (Medium) Resolution: 100dpi x 100dpi Attached file is scanned image in PDF format. Use Acrobat(R)Reader(R) or Adobe(R)Reader(R) of Adobe Systems Incorporated to view the document. Adobe(R)Reader(R) can be downloaded from the following URL: Adobe, the Adobe logo, Acrobat, the Adobe PDF logo, and Reader are registered trademarks or trademarks of Adobe Systems Incorporated in the United States and other countries. <https://smex-ctp.trendmicro.com:443/wis/clicktime/v1/query?url=http%3a%2f%2fwww.adobe.com&umid=8873987f-3cb9-48c6-b1c8-9aa2ba6a44c9&auth=c302d29ff7906effa60127fd92782ca6bfab614f-7a8ecfa338885f498d65a0d52039ed901e286590>

The following email addresses also received a copy of this email:

A copy of the uploaded files will be sent to:

- glinskilaw@wavecable.com
- timw@masoncountywa.gov
- timh@masoncountywa.gov

**Note: The Filing Id is 20220901101517SC412973**